

User Manual

Keywatt 19 Trolley



DUM016199-EN_V002c

ies
Beyond Charging

www.ies-synergy.com

The information provided in this documentation contains general descriptions and/or technical characteristics of the performance of the products contained herein. This documentation is not intended as a substitute for and is not to be used for determining suitability or reliability of these products for specific user applications. It is the duty of any such user or integrator to perform the appropriate and complete risk analysis, evaluation and testing of the products with respect to the relevant specific application or use thereof. Neither IES Synergy nor any of its affiliates or subsidiaries shall be responsible or liable for misuse of the information contained herein. If you have any suggestions for improvements or amendments or have found errors in this publication, please notify us.

You agree not to reproduce, other than for your own personal, noncommercial use, all or part of this document on any medium whatsoever without permission of IES Synergy, given in writing. You also agree not to establish any hypertext links to this document or its content. IES Synergy does not grant any right or license for the personal and noncommercial use of the document or its content, except for a non-exclusive license to consult it on an “as is” basis, at your own risk. All other rights are reserved.

All pertinent state, regional, and local safety regulations must be observed when installing and using this product. For reasons of safety and to help ensure compliance with documented system data, only the manufacturer should perform repairs to components.

When devices are used for applications with technical safety requirements, the relevant instructions must be followed.

Failure to use IES Synergy software or approved software with our hardware products may result in injury, harm, or improper operating results.

Failure to observe this information can result in injury or equipment damage.

© 2020 IES Synergy. All rights reserved.

Table of content

1. Safety notes	4
Notice	4
Please note	4
2. About the manual	5
Purpose of this manual	5
Document scope	5
Related documents	5
User comments	5
3. General Safety instructions	6
4. Overview	7
External view	7
Internal door view	8
5. Specification	9
Technical specification	9
Compliance	11
6. Handling and storage instructions	12
Storage	12
Transport	12
7. Installation	13
Visual inspection	13
Installation rules	13
Plug connections	14
AC input connector	14
DC output connector	15
8. Charger operation	16
Front panel	16
Rear Panel	16
Starting up	17
Charge with COMBO 1 or COMBO 2 connector	19
Charge with CHADEMO connector	23
Charge with GB connector	26
Charge error messages	29
Emergency Stop messages	29
List of error messages	30
9. Cleaning	32
10. Protecting the environment	33
Recycling Packaging	33
End-of-Life Recycling	33

1. Safety notes

Notice

Read these instructions carefully, and look at the equipment to become familiar with the device before trying to install, operate, or maintain it. The following special messages may appear throughout this documentation or on the equipment to warn of potential hazards or to call attention to information that clarifies or simplifies a procedure.



The addition of this symbol to a Danger hazard statements indicates that an electrical hazard exists, which result in personal injury if the instructions are not followed.



This is the safety alert symbol. It is used to alert you to potential personal injury hazards. Obey all safety messages that follow this symbol to avoid possible injury or death.

DANGER

DANGER indicates an imminently hazardous situation which, if not avoided, **will result** in death or serious injury.

WARNING

WARNING indicates a potentially hazardous situation which, if not avoided, **can result** in death or serious injury.

CAUTION

CAUTION indicates a potentially hazardous situation which, if not avoided, **can result** in minor or moderate injury.

NOTICE

NOTICE is used to address practices not related to physical injury.

Please note

Electrical equipment should be installed, operated, serviced, and maintained only by qualified personnel. No responsibility is assumed by IES Synergy for any consequences arising out of the use of this material.

A qualified person is one who has skills and knowledge related to the construction and operation of electrical equipment and its installation, and has received safety training to recognize and avoid the hazards involved.

2. About the manual

Purpose of this manual

Technical documentation is an integral part of a product. Until it is disposed of, always keep the technical documentation close to the unit at hand, as it contains important information. Provide technical documentation to the person concerned if you sell, assign or lend the product.

This guide aims to provide informations needed for installation, use and end-of life of the charger Keywatt 19 Trolley. This guide must be read in integrality with others related documents. This guide is intended for users of the charging station.

Document scope

This guide concerns the following charging station :

- Art/N : TROLLEY 19KW DC CHARGER

Related documents

Document title	Reference
User Manual	DUM016199-EN
Service Manual	

User comments

We invite you to write us to communicate any inaccuracies or omissions, or to make general comments or suggestions regarding the quality of this manual.

3. General Safety instructions

NOTICE

SAVE THIS MANUAL



- To ensure proper and safe operation, please read these user instructions carefully and keep them for future reference.
- This manual contains important instructions for the DC quick charger that shall be followed during installation, operation and maintenance of the unit.
- This equipment shall be installed, adjusted, and serviced by qualified electrical personnel familiar with the construction and operation of this type of equipment and associated hazards.

Failure to follow these instructions may result in death, serious injury or equipment damage.

⚠ DANGER



RISK OF ELECTRIC SHOCK, INJURY, AND/OR BURNING

- Only qualified, trained and authorized people will repair, replace or adjust this equipment.
- Do not let a child play near the product.
- This charger may only be used on a non-flammable surface such as concrete or similar.
- Do not open the front cover at any time while input power is present.
- Do not operate the unit while the cabinet door is opened or unlocked.
- Do not use this product if the cables (input or output) are frayed, have damaged insulation or any other signs of damage.
- Do not use this product if the enclosure or the Electrical Vehicle Supply Equipment (EVSE) connectors are broken, cracked, opened or shows any other indication of damage.
- Do not use a cord extension set or second cable assembly in addition to the cable assembly for the connection of the EV to the EVSE.

Failure to follow these instructions will result in death or serious injury

4. Overview

External view

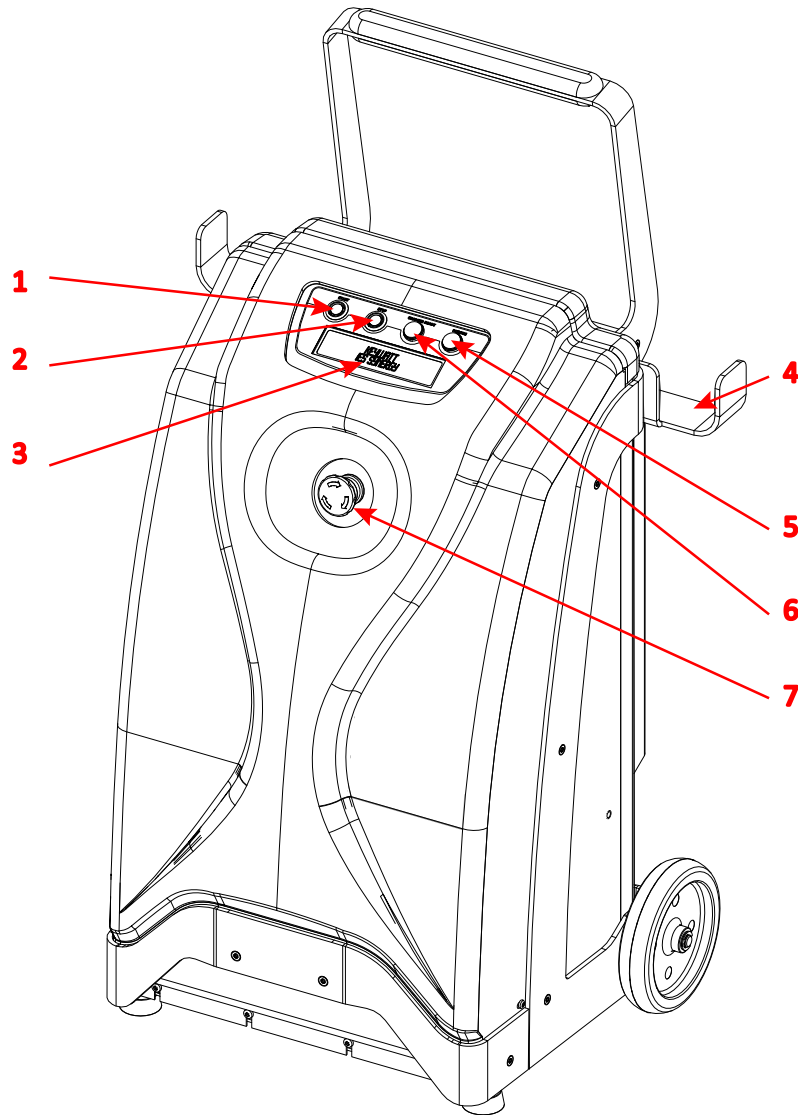

Position	Description
1	Start button
2	Stop button
3	Display
4	Cord bracket
5	Indicator light
6	Indicator light
7	Emergency stop button

Note: May change depending on version or technical modification

Internal door view

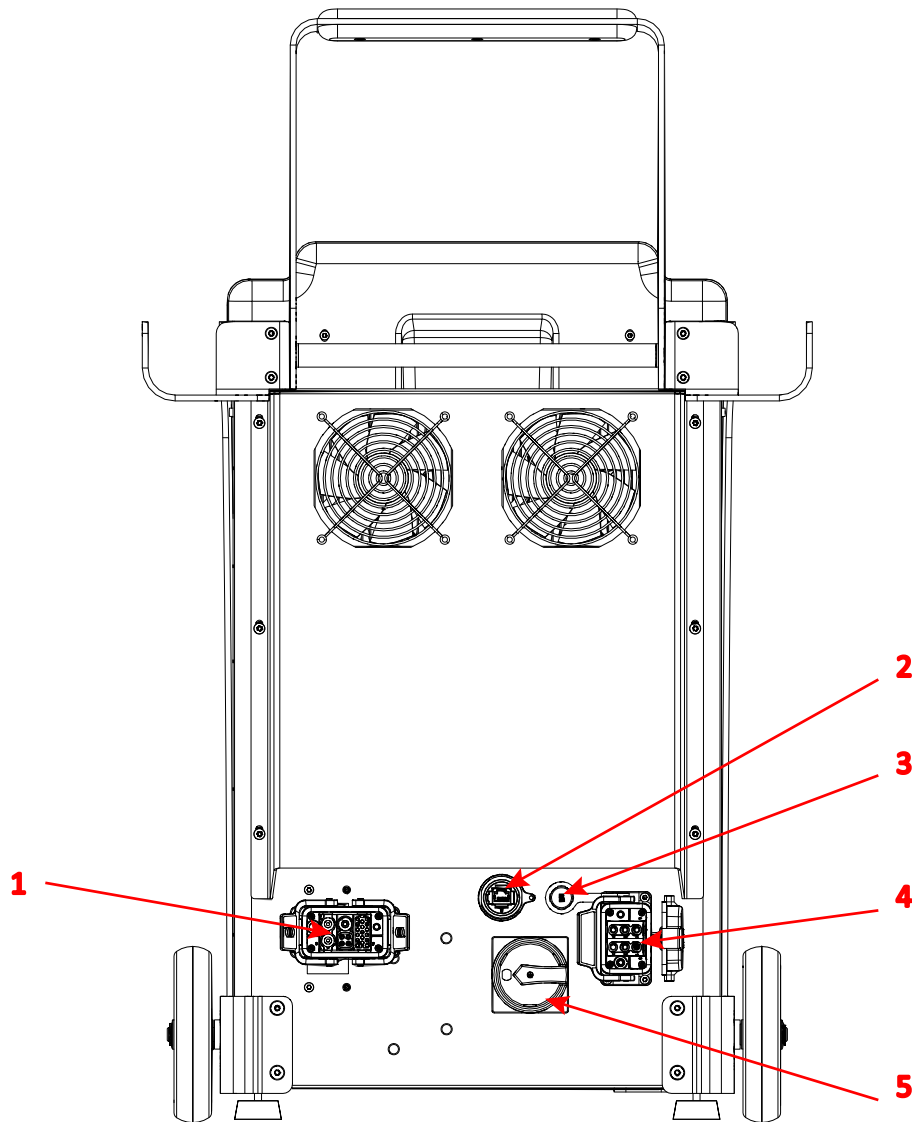

Position	Description
1	DC output Harting connector
2	Ethernet socket
3	USB socket
4	AC input Harting connector
5	Mains input switch

Note: May change depending on version or technical modification

5. Specification

Technical specification

Mains supplies 3-phase L1/L2/L3 + GND 3x400V _{AC} (19kW)			
Mains 3-phase voltage range	V _{AC}	400 V _{AC}	± 10%
Earthed electrical system	TT or TN		
Frequency range	f	50/60 Hz	± 10%
Maximum input current	I _{AC}	32A	Max
Power Factor	PF	0,93	Nom
Efficiency	η	94 %	Nom
Harmonic current @ nominal network voltage	THDi	37 %	Max
Internal AC input protection			
Inrush current limitation per phase	I _{INRUSH LIMIT}	< 3 x I _{AC}	Max
Rated Current Circuit Breaker	I _{BREAK} Rating	50A	typ
Breaking capacity of breaker	I _{BREAK} Capacity	6kA	Max
Max earth leakage current	I _{LEAKAGE}	< 3,5 mA	Max
Emergency button connection	Yes		
Overvoltage (IEC60664-1)	OV III		
Insulation protection Class (IEC6103)	Class II	2500V _{AC}	Min
Internal DC Output			
Output voltage	V _{DC_max}	500 V _{DC}	Max
	V _{DC_min}	200 V _{DC}	Min
Output current	I _{DC_max}	60A ⁽¹⁾⁽²⁾	Max
	I _{DC_min}	1A	Min
Max Output Power	P _{OUT}	19kW	Max
Output connector (charging station side)	Swapped vehicle cable		
Car Plug coupler	COMBO1 / COMBO2 / CHAdeMO / GB		
Output cable length	-	4	Meters
Internal DC output protection			
Hardware and software short circuit protection	Yes		
Over current protection	-	100A	
Over voltage protection	adjustable	+ 10 % Max	
Internal over temperature protection	-	60	°C
Reverse polarity protection	Yes		
DC output Contactor	Yes (2 poles)		
Rated Current Fuse (output)	I _{FUSE}	100	A
Galvanic isolation	V _{input / output}	4000	V _{DC}
Max time for DC line discharge < 60V	T _{<60V}	1	s
Embedded Insulation device			
Response time (tan)	< 3sec. for asymmetrical fault < 62sec. for symmetrical fault		
Self test time	At power on and every 60s during charge		

Embedded Insulation device	
Internal resistance Ri of the measuring circuit	1.5Mohms permanent 750Kohms continuous measurement 300Kohms during simultaneous switching measurement
Measurement method	Continuous and switching measurement resistor method
Measuring current Im	< 1,4mA at RF=0
Measurement range (Ran)	20Kohms...300Kohms
Relative uncertainty	±15%
Line L+/L- Voltage (Un)	DC 200V...500V
System leakage capacity Ce	≤ 1μF : response value (Ran) and time (tan) are not guaranteed for capacity above 1μF
Parallelization	⚠ Warning: Do not connect the insulation monitor device (IMD) in parallel !! Response value (Ran) and time (tan) are not guaranteed.

General & dimensions			
External dimensions (mm)	H x W x D	945 x 507 x 45 mm	
Weight (without cable, or bracket)	kg	48kg	Max
Type of installation	Trolley (2 wheels)		
Protection type (EN60529)	IP	IP54	
Cooling systems	Heatsink with forced air flow by fans IP54 without air filter		
Noise (1m, all direction)	Db(A)	65dbA (1m)	

Climatic & Environment constraints			
Operating temperature (with derating)	-20°C to +40°C ⁽³⁾		
Storage temperature	-40°C to +70°C		
Relative humidity (without condensation)	RH	10% to 95%	
Installation altitude	Alt	2 000m	Max

Norms & standards	
EC Low voltage EC directive (LVD)	2014/35/EU
EC Electromagnetic Directive (EMC)	2014/30/EU
Electric vehicle conductive charging system part 1 General requirement	IEC 61851-1
Electric vehicle conductive charging system part 23 DC Electric vehicle charging station	IEC 61851-23
EMC requirement for OFF board electric vehicle charging system	IEC 61851-21-2
Insulation Monitor Device (IMD)	IEC 61557-1 & IEC 61557-8
RoHS	2015/863/EU
Declaration of conformity CE ⁽⁴⁾	Yes

⁽¹⁾ Max output current will be adapted versus maximum carrying current of the vehicle plug.

⁽²⁾ Output current can be even reduced with the power derating versus temperature.

⁽³⁾ Potential derating above 25°C.

⁽⁴⁾ CE marking affixed on the product attest the conformity of the product with applicable requirements of relevant Community harmonization legislation.

Compliance

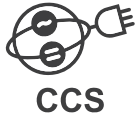

6. Handling and storage instructions

Storage

The charging stations are supplied in individual wood crate. When commissioning the product, all the protection for transport must be removed before energization.

Keep the charging station in its original packaging in an appropriate place:

- placed on dry ground or on a sheet to protect it from damp,
- sheltered from dust, inclement weather and sunlight.

Storage temperature: -40°C to +70°C

Humidity: 10% to 95% without condensation

During prolonged storage, check the state of the charging station packaging regularly.

Do not store the charging station for more than a year without powering it up, to avoid the deterioration of non-energized electronic components.

Transport

Throughout the transport phase, take all necessary measures to keep the pallet stable.

NOTICE



RISK OF DAMAGE TO THE CHARGING STATION

- Improper storage or handling may cause damage to the unit.
- Failure to follow these instructions can result in equipment damage.**

CAUTION



RISK OF INJURY DUE TO DROPPING OR FALLING

- Follow specified procedures for hoisting operations.
 - Take measures to prevent falling when you carry or transfer the unit.
- Failure to follow these instructions will result in minor or moderate injury.**

7. Installation

Visual inspection

Before switching on the power, check that the charging station has not suffered any damage during transport. If there is any sign of damage, do not connect the charging station to the input power supply. To do so would lead to a risk of electric shock and injury.

Installation rules

It is advisable to leave 40cm free space on each side of the charging station if it is surrounded by a wall. This free space is mandatory for charging station's ventilation. Never block air flow.

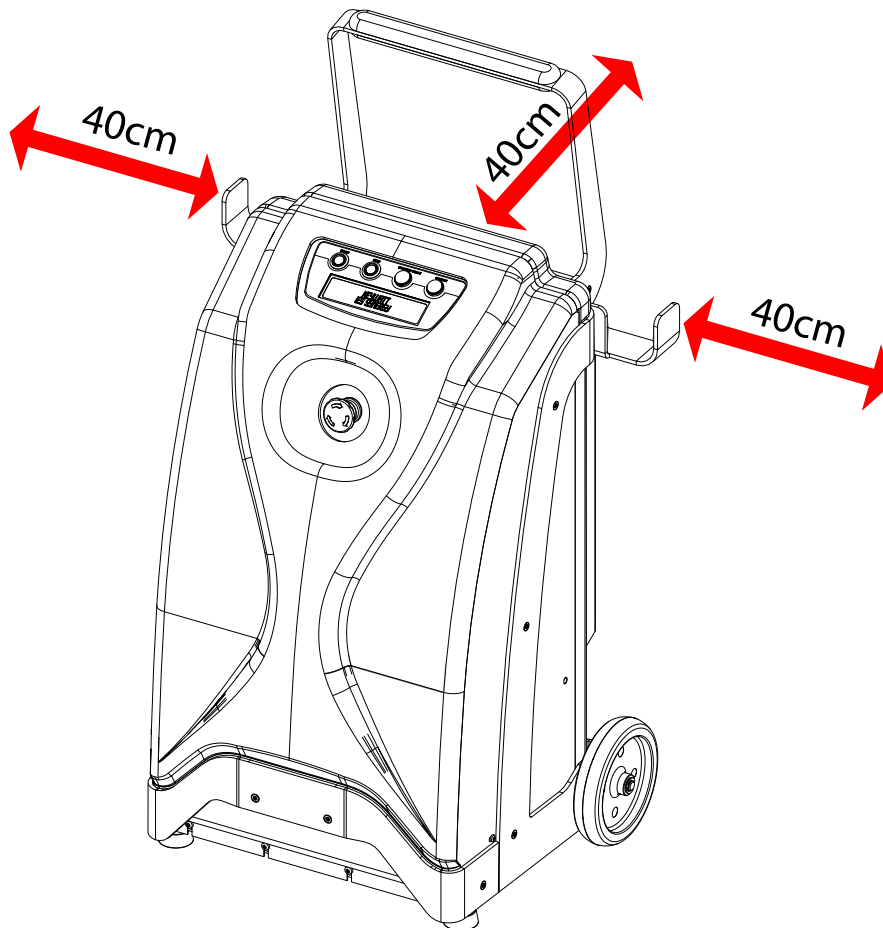

Note: All pertinent state, regional, and local safety regulations must be observed when installing and using this device.

Note: The manufacturer cannot be held responsible for failure to follow the instructions given in this instruction sheet.

NOTICE



PREMATURE AGEING OF THE CHARGING STATION

- Do not install charging stations outside where they are exposed to direct sunlight and inclement weather.

Failure to follow these instructions can result in accelerate power derating.

Plug connections

⚠ WARNING



HAZARD OF ELECTRIC SHOCK OR DAMAGE TO THE CHARGING STATION

- Hazardous voltages may be present on both the charger input and output connections.
- Do not use this product if the cables (input or output) are frayed, have damaged insulation or any other signs of damage.
- A cord extension set or second cable assembly or adaptor must not be used in addition to the coupler/cable assembly for the connection into the vehicle.

Failure to follow these instructions will result in death or serious injury.

AC input connector

Use the AC input cable ref FLPLA012536 for this equipment.

5-wire plug :
MENNEKES AM-TOP 32A 3P+N+T 400V plug

4m

FLPLA012536



If the power cable is damaged it must be replaced with a new cable.

⚠ WARNING



HAZARD OF ELECTRIC SHOCK OR DAMAGE TO THE CHARGING STATION

- To protect against electric shocks in the event of a fault, make sure that the protective earth conductor of the mains power supply is correctly connected before switching on the power.
- The input must be connected to the power supply by a CCID (Charging Circuit Interrupting Device) rated 32A with an opening contact gap for all poles that provides full disconnection in Category III overvoltage.

Failure to follow these instructions will result in death or serious injury.

DC output connector

⚠ WARNING



HAZARD OF ELECTRIC SHOCK OR DAMAGE TO THE CHARGING STATION

- Lethal voltage. The DC source may supply 500V continuous voltage. Touching the connected circuit or the output terminal when the power is on may cause death.
- A cord extension set or second cable assembly or adaptor must not be used in addition to the coupler/cable assembly for the connection into the vehicle.

Failure to follow these instructions will result in death or serious injury.

Output cable and connector types are:

COMBO 1 Output cable		
4m	FLPLA016829	
COMBO 2 Output cable		
4m	FLPLA016827	
CHADEMO Output cable		
4m	FLPLA016828	

8. Charger operation

Front panel

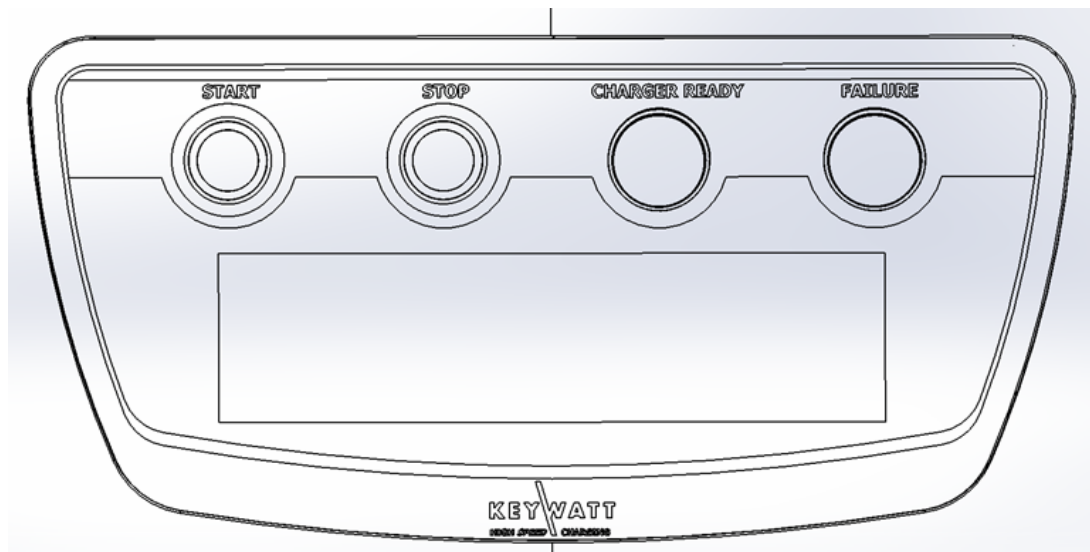

Rear Panel

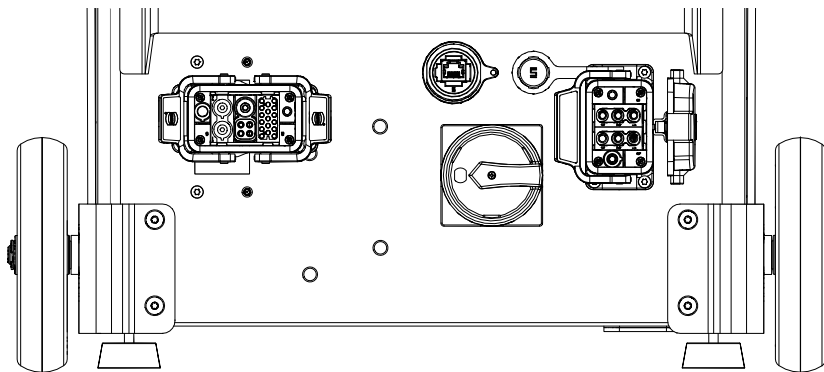

All external circuits connected to the product with USB or ethernet socket must be SELV (Safety Extra Low Voltage) and Limited Power Sources less than 15VA and meeting the requirements of Chapters 2.2 and 2.5 of IEC60950-1:2005+/A1:2010+/A2:2013 and N60950-1:2006+/A11:2009+/A1:2010+/A12:2011+/A2:2013.

Mains input switch is not a safety isolating switch.

Starting up

⚠ WARNING



RISK OF ELECTRIC SHOCK, INJURY, AND/OR BURNING

Make sure no vehicle is connected before starting up the charger.

Failure to follow these instructions can result in death or serious injury

Turn the disconnecting device to the position "I ON" to power up the charger.

The charger displays its name after a startup phase represented by "...":

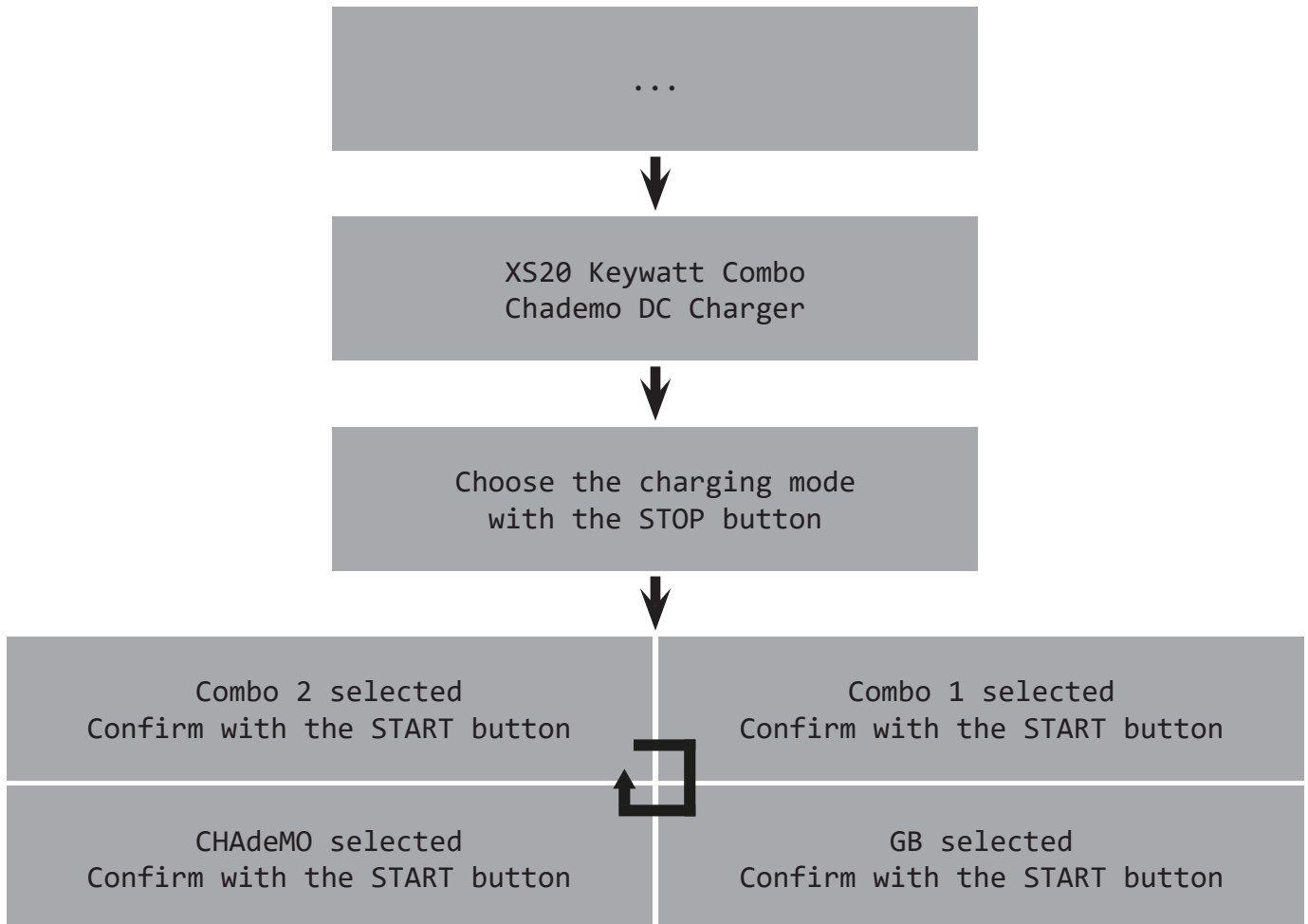

If the charger does not start:

1. Remove the cables connected to the charger.
2. Remove the T25 fastening screws (x6) ① of the circuit breaker access cover.
3. Remove the access cover ② to the circuit breakers ③.

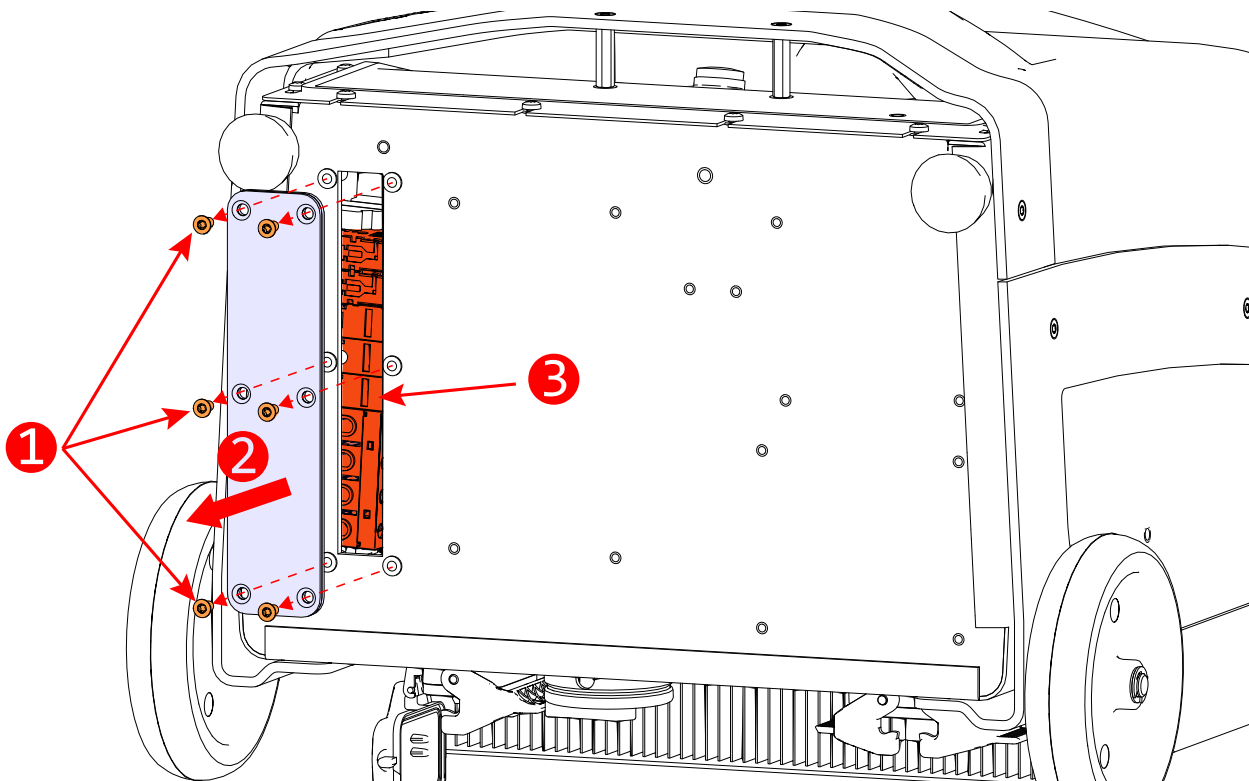

4. Check that the circuit breakers (3-phase input circuit breaker ①, RCD breaker ② and 12/24 V supplies circuit breaker ③) are in upper position, if not, put them back to upper position using a flat-head screwdriver to access the switches.

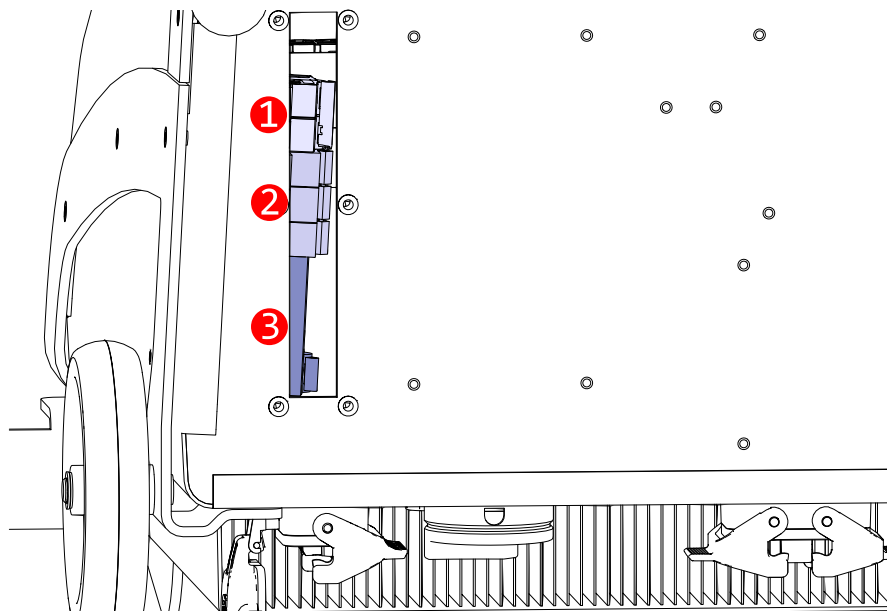

5. Reinstall the access cover.
6. Tighten the T25 fastening screws of the circuit breaker access cover.
7. Reconnect the cables to the charger.
8. Check that the charger starts. If it is still not starting, contact the after sales service at support@ies-synergy.com

Charge with COMBO 1 or COMBO 2 connector

The charger performs an internal check and initialisation.
Please wait for a few seconds.

Initialisation...

→ The Start button flashes for 1 second.

When initialisation is successful:

Connect vehicle
to start charge.

⊗ In case of error (two types of internal fault):

Pwr module failure
0 OK and 2 Fail

No power module

Step 2 Start a new charge

Connect the charging plug to the vehicle (secure firmly).

→ The charge status indicator flashes for 1 second.

The charger is waiting to communicate with the vehicle.

Vehicle connected
Wait for EV communication

Communication in progress...

Communication has been established.

Then the charger performs the insulation test.

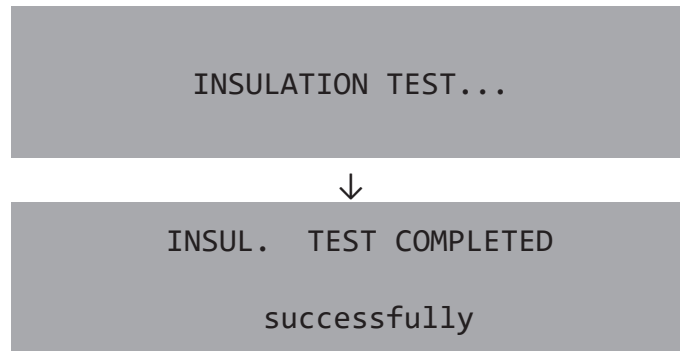

⊗ If there is an insulation failure:

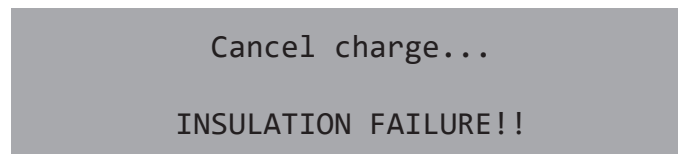

Then the charger performs the pre-charge phase.

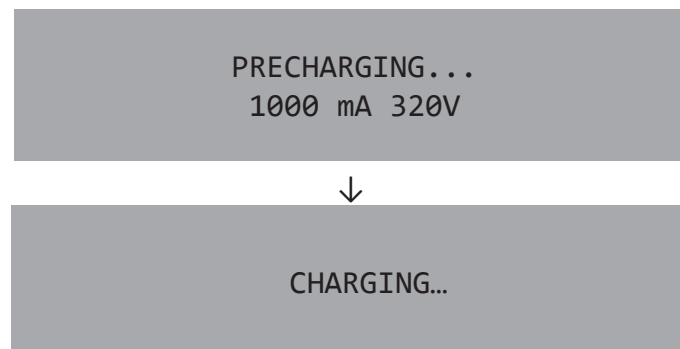

When the pre-charge target is reached and after receiving permission to charge, the charger displays:

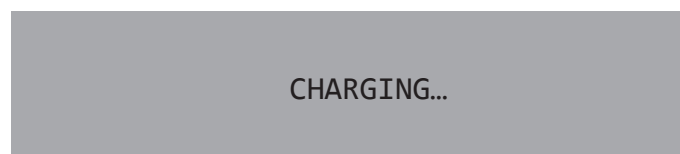

Charging is now in progress.

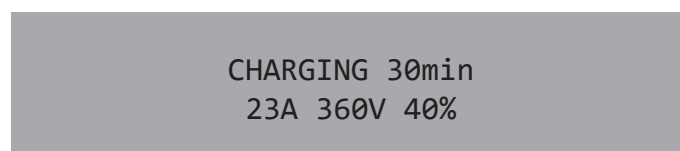

The display indicates the charge duration, the charging current and voltage and the current battery charge status. The user can display other parameters and information by pressing the start button.

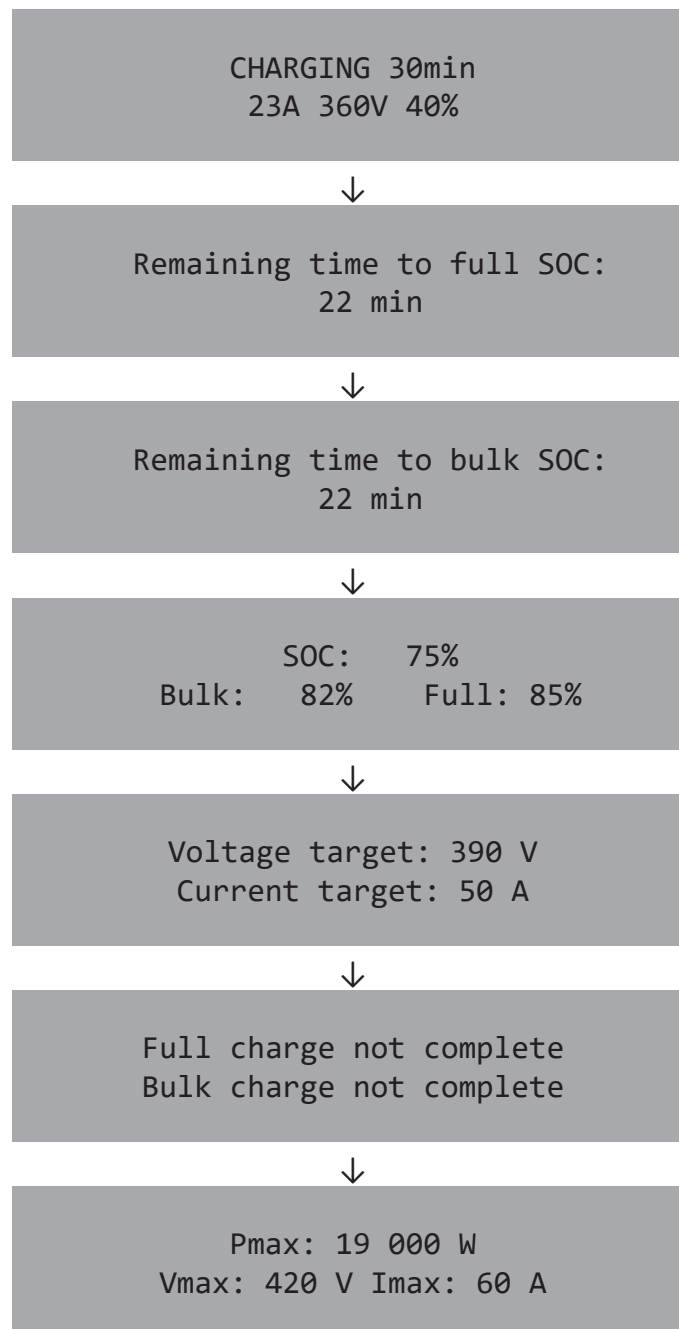

When charging is complete:

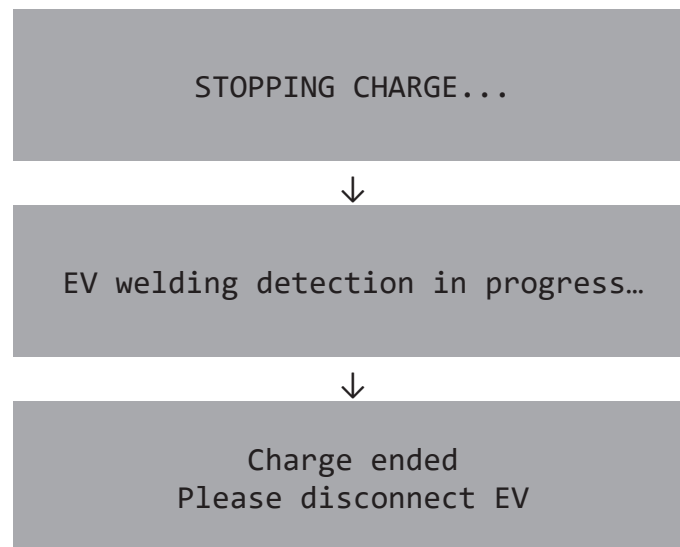

The charger performs the stop charge procedure.

Charging is stopped either by the vehicle or by the operator pressing the “OFF” button.

→ The charge status indicator flashes slowly for 2 seconds.

Charge with CHADEMO connector

The charger performs an internal check and initialisation.
Please wait for a few seconds.

Initialisation...

→ The Start button flashes for 1 second.

When initialisation is successful:

Connect vehicle and
press ON to start.

⊗ In case of error (two types of internal fault):

Pwr module failure
0 OK and 2 Fail

No power module

Step 2 Start a new charge

Connect the charging plug to the vehicle (secure firmly).
Then press the "START" Button.

→ The charge status indicator flashes for 1 second.

The charger is starting to communicate with the vehicle.

STARTING SEQUENCE



STARTING COMMUNICATION

Communication has been established.

LOCKING CONNECTOR

⊗ If there is a communication fault:
Communication problem with BMS

START COMMUNICATION
Battery incompatible

START COMMUNICATION
Battery malfunction

Then the charger locks the charging plug and performs the insulation test.

INSULATION TEST...



INSUL. TEST COMPLETED
successfully

⊗ If there is an insulation failure:

Cancel charge...
INSULATION FAILURE!!

Charging is now in progress.

CHARGING 30min
23A 360V 40%

The Display indicates the time left, the charging current and voltage and the current battery capacity.
→ The charge status indicator flashes slowly for 2 seconds.

When charging has finished:

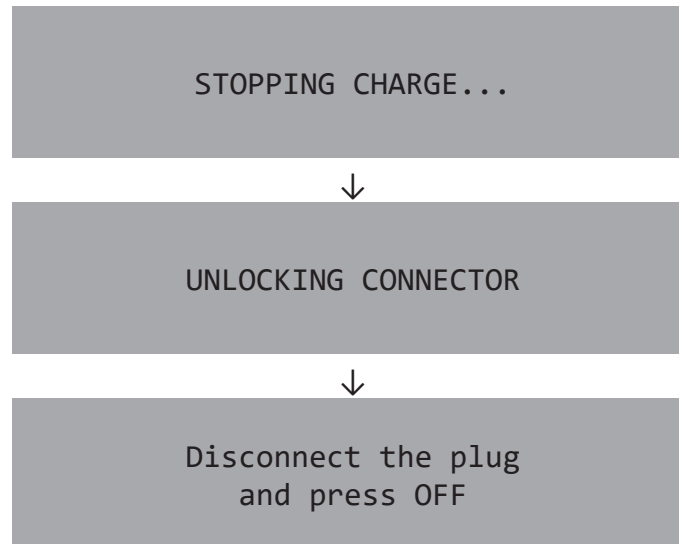

The charger performs the stop charge procedure.

Charging is stopped either by the BMS or by the operator pressing the "STOP" button.

→ The charge status indicator flashes slowly for 2 seconds.

Charge with GB connector

The charger performs an internal check and initialisation.
Please wait for a few seconds.

Initialisation...

→ The Start button flashes for 1 second.

When initialisation is successful:

Connect vehicle
to start charge.

⊗ In case of error (two types of internal fault):

Pwr module failure
0 OK and 2 Fail

No power module

Step 2 Start a new charge

Connect the charging plug to the vehicle (secure firmly).

→ The charge status indicator flashes for 1 second.

Vehicle connected
Press START

Connect the charging plug to the vehicle (secure firmly).
Then press the "START" button

Then the charger performs the insulation test.

INSULATION TEST...



INSUL. TEST COMPLETED
successfully

⊗ If there is an insulation failure:

Cancel charge...
INSULATION FAILURE!!

Then the charger performs the pre-charge phase.

PRECHARGING...
1000 mA 320V



CHARGING...

When the pre-charge target is reached and after receiving permission to charge, the charger displays:

CHARGING...

Charging is now in progress.

CHARGING 30min
23A 360V 40%

The display indicates the charge duration, the charging current and voltage and the current battery charge status. The user can display other parameters and information by pressing the start button.

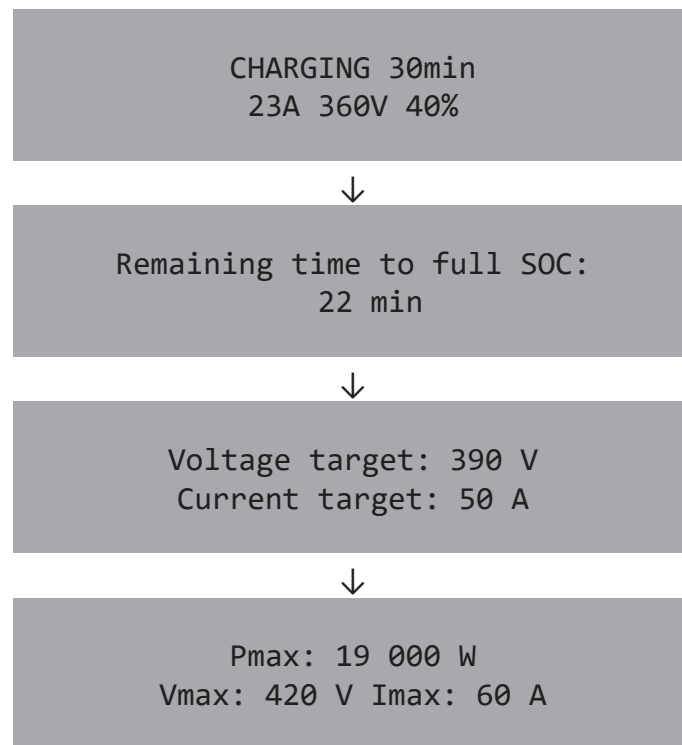

When charging is complete:

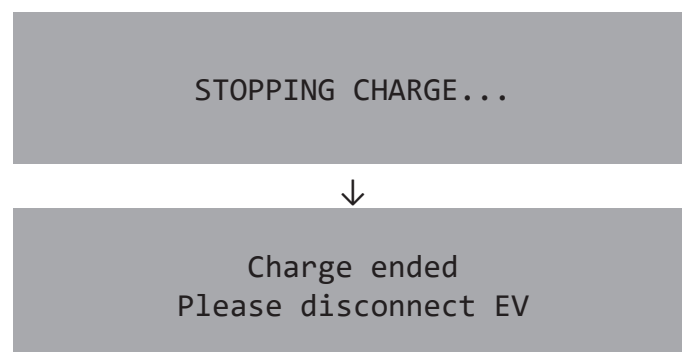

The charger performs the stop charge procedure.

Charging is stopped either by the vehicle or by the operator pressing the "OFF" button.

→ The charge status indicator flashes slowly for 2 seconds.

Charge error messages

The various displays when an error has occurred during charging.

<p>STOPPING CHARGE... Error message</p>	<p>Generic charge error</p> <p>The "Error message" will indicate the cause of the fault</p>
<p>Vout applied! LOCK Maintenance</p>	<p>Fault detected when unlocking the CHAdeMO plug</p>
<p>discon. & press OFF Error message</p>	<p>End of charging display when an error occurred during charging</p>

Emergency Stop messages

The Emergency Stop indicator flashes for 1 second.

<p>Emergency Stop...</p>	<p>Manual Emergency Stop</p>
<p>Emergency Stop!!</p>	<p>Software Emergency Stop</p>
<p>Emergency Stop!! PSU connection lost</p>	<p>Internal Fault Emergency Stop</p>

List of error messages

Message	Description
"Emergency_Stop"	Emergency Stop pushbutton has been activated or output cable not connected at the back of the charger
"ERR Vout_at_start"	Abnormal output voltage at charger start up
"Out_Pwr_Switch_Fail."	Defective Charger DC output contactor
"Can_Data_invalid"	Incorrect data frame sent by the vehicle on CAN Vehicle fails to update output current request when charging starts
"Can_Frame_absent"	No CAN communication
"ShortCircuit"	2 cases - Output current above I _{max} . - Output current above 5 amps during insulation test.
"OverVoltage"	Charger output voltage exceeds maximum voltage limit
"ChargerOverHeating"	Cooling defect. Internal power modules have reached the maximum permitted operating temperature
"Over Limit I"	The vehicle requires too high a current according to the start of charging calculation.
"PSU Absent"	No response from power supervisor (internal fault)
"PSU Timeout Change"	Power supervisor timeout during state transition (internal fault)
"PSU bad state"	Power supervisor goes into incoherent state (internal fault)
"Connector_Lock"	CHAdEMO plug locking coil defect.
"BatteryIncompatib."	Battery voltage range not suitable for the charger
"BatteryMalfunction"	Vehicle battery fault: - No CAN communication at charge start-up. - Incorrect current or voltage data. - Abnormal voltage at charge start-up.
"ChargingStopCtl"	Charge start-up denied (CAN or physical i/o line).
"VehicleShiftPosition"	Gearshift is not in neutral (vehicle fault)
"VehicleOtherFaults"	Vehicle fault. Check vehicle supervisor.
"BatteryOverVoltage"	Overvoltage detected by the vehicle.
"BatteryUnderVoltage"	Too low a voltage detected by the vehicle.
"BatteryCurrentDiff."	Current measurements mismatch from vehicle measurement and charger CAN data, detected by the vehicle.
"HighBatteryTemp."	Battery overheating detected by the vehicle.
"VoltageDifferential"	Voltage measurements do not match vehicle measurements and charger CAN data, detected by the vehicle.
"InsulationFailure"	Earth fault current detected by charger
"ChargerMalfunction"	During battery charging - Charger power supervisor (not CCU) stops charge, after detecting output overvoltage. - Charge aborted by pressing "OFF" button.
"PSU ERROR ARU"	Software emergency stop requested by the power supervisor (internal).
"PSU Modules COM"	Power module communication lost (internal).
"PSU CCU COM"	Communication interruption between power supervisor and CCU (internal).

Message	Description
"PSU OVERVOLTAGE"	Overvoltage detected by power supervisor (internal).
"PSU OVERHEATING"	Overheating detected by power supervisor (internal).
"PSU COHERENCY"	Coherency error detected by power supervisor (internal).
"PSU INSULATION"	Earth fault detected by power supervisor (internal).
"PSU LIMIT Vmax"	Output voltage limit exceeded (+5V) detected by power supervisor (internal).
"PSU SHORT CIRCUIT"	Output short-circuit detected by power supervisor (internal).
"PSU Bad Vred"	Input voltage out-of-range detected by power supervisor (internal).
"OverCurrent"	Output current exceeds the maximum value
"ERR EV Charge Status Not Ready"	The vehicle requests a charge but its status is not ready.
"ERR Bad Pilot State during charge"	The pilot changes from status C during charging
"EV bad pilot state at start"	Pilot status is not A or B at start
"Error EV Not Ready"	The EV ready flag is not ready
"Error Timeout : EV Session Setup Request not received"	The charger has not received the session setup request (timeout is 20 s)
"Error Timeout : EV Ready to Charge State not received"	The charger has not received the ready to charge flag (Timeout is 40s)
"Error No message or Client Dis-connected"	The charger has detected that the EV is present, but the EV has not sent a request.

9. Cleaning

Clean the outside of the terminal can be done while it is on, however, do not clean the terminal when an electric vehicle is connected to the terminal.

Cleaning the terminal is made with a dry cloth or possibly soapy water, it is to do 2 times a year. Cleaning with solvent should be avoided to ensure good behavior in time of painting.

⚠ CAUTION



RISK OF DAMAGE TO THE TERMINAL

- DO NOT use a high pressure jet to clean the device.
- Preserve the terminal from contact with gasoline, diesel and other automotive fluids.
- DO NOT use solvents to clean the terminal.

Failure to follow these instructions can cause damage.

Every six months,

- Conduct a visual inspection of the air inlet of the charging station and ensure that they are not clogged.
- Conduct a visual inspection of the charging cable and ensure that cable does not show any visual damage or deformation.
- Conduct a visual inspection of the charging gun and ensure that gun does not show any visual damage, arcing or rust.

Every year, conduct a visual inspection of the state of the lightning protections and ensure that they are not damages.

⚠ WARNING



HAZARD OF ELECTRIC SHOCK, EXPLOSION, OR ARC FLASH

- To avoid danger of electrical shock or injury, turn off power at the panel board or load center before working on the equipment or removing any component. Do not remove circuit protective devices or any other component until the power is turned off.
- Disconnect electrical power to the harging station before any maintenance work to ensure that it is separated from the supply of AC mains. Failure to do so may cause physical injury or damage to the electrical system and charging unit.
- Maintenance of the charging station shall be conducted only by a qualified technician.

Failure to follow these instructions will result in death or serious injury.

10. Protecting the environment

Recycling Packaging

The packaging materials from this equipment can be recycled. Please help protect the environment by recycling them in appropriate containers.

Thank you for playing your part in protecting the environment.

End-of-Life Recycling

This product have been optimized to reduce the amount of waste produced at the end of their useful life and for better recovery of component parts and materials when following customary processing procedures.

Products have been designed so that their components can be processed by conventional procedures: decontamination where this is recommended, reuse and/or dismantling in order to improve recycling performance, and crushing to separate out the rest of the materials.

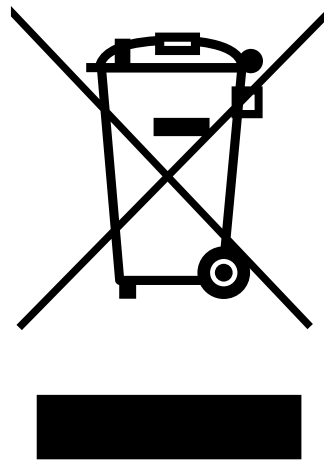

IES Synergy (Head Office)

615, Avenue de la Marjolaine
34130 Saint Aunès
France
Tel: +33 (0)4 99 13 62 80
Fax: +33 (0)4 99 13 62 81

www.ies-synergy.com

DUM016199-EN_V002c
September 2024

As standards, specifications, and designs change from time to time, please ask for confirmation of the information given in this publication.

